

# Workshop Caliper









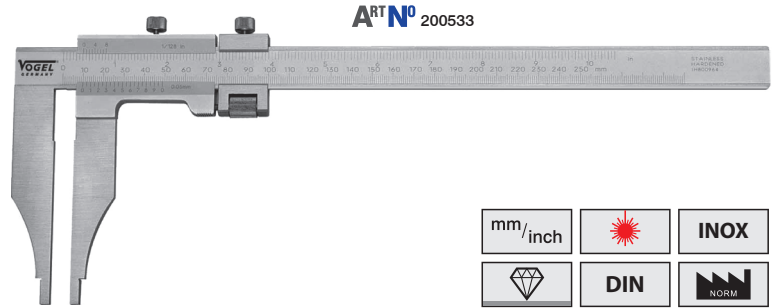











DIN 862 or in special sizes acc. to workshop grade

ARTN<sup>o</sup> 200503

## • precision class

- stainless steel, hardened
- scale and vernier satin chrome finish, laser engraved scale
- jaws finely ground
- offset jaws for inside measurements
- with or without fine adjustment, without knife points
- with fixing screw
- mono block vernier
- with identification number
- 0 – 600 mm R mm-pitch
- < 600 mm R cm-pitch



		 mm / inch	 bottom mm	 top inch	 mm	 mm	 ø mm	
200501	200531	200 / 8	0.05	1/128	65	—	10	on request
200502	200532	250 / 10	0.05	1/128	80	—	10	on request
200503	200533	300 / 12	0.05	1/128	100	—	10	on request
—	200533-1	300 / 12	0.05	1/128	150	—	20	on request
200504	200534	400 / 16	0.05	1/128	100	—	20	on request
200505	200535	500 / 20	0.05	1/128	150	—	20	on request
—	200535-1	500 / 20	0.05	1/128	200	—	20	on request
200505-2	200535-2	500 / 20	0.05	1/128	300	—	20	on request
200506	200536	600 / 24	0.05	1/128	150	—	20	on request
—	200536-1	600 / 24	0.05	1/128	200	—	20	on request
—	200536-2	600 / 24	0.05	1/128	300	—	20	on request
200508	200538	800 / 32	0.05	1/128	150	—	20	on request
—	200538-1	800 / 32	0.05	1/128	200	—	20	on request
—	200538-2	800 / 32	0.05	1/128	300	—	20	on request
200510	200540	1000 / 40	0.05	1/128	150	—	20	on request
—	200541	1000 / 40	0.05	1/128	200	—	20	on request
—	200542	1000 / 40	0.05	1/128	300	—	20	on request
—	200543	1000 / 40	0.05	1/128	500	—	20	on request
—	200551	1250 / 50	0.05	1/128	200	—	20	on request
 200512	 200552	1500 / 60	0.05	1/128	200	—	20	on request
—	 200552-1	1500 / 60	0.05	1/128	300	—	20	on request
 200513	 200553	2000 / 80	0.05	1/128	200	—	20	on request
—	 200553-1	2000 / 80	0.05	1/128	300	—	20	on request
 200514	 200554	2500 / 100	0.05	1/128	200	—	20	on request
 200515	 200555	3000 / 120	0.05	1/128	200	—	20	on request
—	 200555-1	3000 / 120	0.05	1/128	300	—	20	on request